

Haier

HSR3918FI*

HSOBPIF9183

HSOGPIF9183

* = MP, MX, PG, PH, PB, PW



Refrigerator
User Guide

Kühlschrank
Bedienungsanleitung

Réfrigérateur
Mode d'emploi

Frigorifero
Guida per l'utente

Frigorífico
Manual del usuario

Frigorífico
Guia do Utilizador

Koelvriescombinatie
Handleiding

Lodówka
Podręcznik użytkownika

Chladnička
Uživatelská příručka

Hűtőszekrény
Felhasználói útmutató

Ψυγείο
Οδηγίες χρήσης

EN

DE

FR

IT

ES

PT

NL

PL

CZ

HU

EL



EN WARNING: Risk of fire/flammable material.

The symbol indicates there is a risk of fire since flammable materials are used. Take care to avoid causing a fire by igniting flammable material.

DE WARNUNG: Brandgefahr / brennbare Stoffe. Das Symbol weist darauf hin, dass aufgrund der Verwendung von brennbaren Materialien eine Brandgefahr besteht. Achten Sie darauf, dass Sie kein Feuer verursachen, indem Sie brennbare Materialien entzünden.

FR ATTENTION : Risque d'incendie/matériau inflammable. Le symbole indique qu'il y a un risque d'incendie car des matériaux inflammables sont utilisés. Veillez à ne pas provoquer d'incendie en manipulant des matériaux inflammables.

IT AVVERTENZA: Rischio di incendio/materialie infiammabile. Il simbolo indica che esiste un rischio di incendio poiché vengono utilizzati materiali infiammabili. Prestare attenzione a non provocare un incendio dando fuoco a materiale infiammabile.

ES ADVERTENCIA: Riesgo de incendio/material inflamable. El símbolo indica que existe un riesgo de incendio ya que se utilizan materiales inflamables. Proceda con cuidado para evitar encender material inflamable y causar un incendio.

PT AVISO: Risco de incêndio/material inflamável. O símbolo indica que existe risco de incêndio devido ao uso de materiais inflamáveis. Cuidado para evitar provocar um incêndio ao acender material inflamável.

NL WAARSCHUWING: Brandgevaar/ontvlambaar materiaal. Het symbool geeft aan dat er brandgevaar bestaat omdat ontvlambare materialen worden gebruikt. Zorg ervoor dat u geen brand veroorzaakt door het ontsteken van ontvlambaar materiaal.

HU FIGYELEM! Tűzveszély/gyúlékony anyagok. A szimbólum tűzveszélyre utal, mivel a termék gyúlékony anyagokat tartalmaz. Ügyeljen arra, hogy ne okozzon tüzet a gyúlékony anyagok meggyújtásával.

PL OSTRZEŻENIE: ryzyko pożaru/materiały łatwopalne. Symbol oznacza ryzyko pożaru, ponieważ używane są materiały łatwopalne. Należy uważać, aby nie spowodować pożaru przez zapłon materiałów łatwopalnych.

CZ VAROVÁNÍ! Nebezpečí požáru / hořlavý materiál. Symbol označuje nebezpečí požáru, protože se používají hořlavé materiály. Dbejte na to, aby nedošlo k zapálení hořlavého materiálu.

ΕΛ ΠΡΟΕΙΔΟΠΟΙΗΣΗ! Κίνδυνος πυρκαγιάς/εύφλεκτο υλικό. Το σύμβολο υποδεικνύει ότι υπάρχει κίνδυνος πυρκαγιάς δεδομένου ότι χρησιμοποιούνται εύφλεκτα υλικά. Προσέξτε να αποφύγετε την πρόκληση πυρκαγιάς μέσω της ανάφλεξης εύφλεκτου υλικού.



User Manual

Refrigerator-Freezer

HSR3918FI*

HSOBPIF9183

HSOGPIF9183

* = MP, MX, PG, PH, PB, PW

EN

Haier

Thank you for purchasing a Haier Product.

Please read these instructions carefully before using this appliance. The instructions contain important information which will help you get the best out of the appliance and ensure safe and proper installation, use and maintenance.

Keep this manual in a convenient place so you can always refer to it for the safe and proper use of the appliance.

If you sell the appliance, give it away, or leave it behind when you move house, make sure you also pass this manual so that the new owner can become familiar with the appliance and safety warnings.



Legend

Warning – Important Safety information



General information and tips



Environmental information



Disposal

Help protect the environment and human health. Put the packaging in applicable containers to recycle it. Help to recycle waste of electrical and electronic appliances. Do not dispose appliances marked with this symbol with the household waste. Return the product to your local recycling facility or contact your municipal office.



WARNING!

Risk of injury or suffocation!

Refrigerants and gases must be disposed of professionally. Ensure that the tubing of the refrigerant circuit is not damaged before being properly disposed of. Disconnect the appliance from the mains supply. Cut off the mains cable and dispose of it. Remove the trays and drawers as well as the door catch and seals, to prevent children and pets to get closed in the appliance.

Old appliances still have some residual value. An environmentally friendly method of disposal will ensure that valuable raw materials can be recovered and used again.

Cyclopentane, a flammable substance not harmful to ozone, is used as an expander for the insulation foam.

By ensuring this product is disposed of correctly, you will help prevent potential negative consequences for the environment and human health, which could otherwise be caused.

For more detailed information about recycling of this product, please contact your local council, your household waste disposal service or the shop where you purchased the product, handled by the professionals.

1 - Safety information.....	4
2 - Intended use.....	9
3 - Product description	12
4 - Control panel.....	13
5 - Use.....	14
6 - Energy saving tips	24
7 - Equipment	25
8 - Care and cleaning.....	27
9 - Troubleshooting.....	30
10 - Installation.....	34
11 - Technical data	39
12 - Customer service	40

Before switching on the appliance for the first time read the following safety hints!:



WARNING!

Before first use

- ▶ Make sure there is no transport damage.
- ▶ Remove all packaging and keep out of children's reach.
- ▶ Wait at least two hours before installing the appliance in order to ensure the refrigerant circuit is fully efficient.
- ▶ Handle the appliance always with at least two persons because it is heavy.

Installation

- ▶ The appliance should be placed in a well-ventilated place. Ensure a space of at least 10 cm above and around the appliance.
- ▶ **WARNING:** Keep ventilation openings, in the appliance enclosure or in the built-in structure, clear of obstruction.
- ▶ Never place the appliance in a damp area or location where it might be splashed with water. Clean and dry water splashes and stains with a soft clean cloth.
- ▶ Do not install the appliance in direct sunlight or in the near of heat sources (e.g. stoves, heaters).
- ▶ Install and level the appliance in an area suitable for its size and use.
- ▶ Make sure that the electrical information on the rating plate agrees with the power supply. If it does not, contact an electrician.
- ▶ The appliance is operated by a 220-240 VAC/50 Hz power supply. Abnormal voltage fluctuation may cause the appliance to fail to start, or damage to the temperature control or compressor, or there may be an abnormal noise when operating. In such case, an automatic regulator shall be mounted.
- ▶ Do not use multi- plug adapters and extension cables.
- ▶ **WARNING:** Do not locate multiple portable socket-outlets or portable power supplies at the rear of the appliance.
- ▶ **WARNING:** When positioning the appliance, ensure the supply cord is not trapped or damaged.
- ▶ Do not step on the power cable.

**WARNING!**

- ▶ Use a separate earthed socket for the power supply which is easy accessible. The appliance must be earthed.

Only for UK: The appliance's power cable is fitted with 3-cord (grounding) plug that fits a standard 3-cord (grounded) socket. Never cut off or dismount the third pin (grounding). After the appliance is installed, the plug should be accessible.

- ▶ **WARNING:** Do not damage the refrigerant circuit.

Daily use

- ▶ This appliance can be used by children aged from 8 years and above and persons with reduced physical, sensory or mental capabilities or lack of experience and knowledge if they have been given supervision or instruction concerning use of the appliance in a safe way and understand the hazards involved.
- ▶ Children shall not play with the appliance.
- ▶ Children aged from 3 to 8 years are allowed to load and unload refrigerating appliances, but not allowed to clean and install the refrigerating appliances.
- ▶ Keep away children under 3 years of age from the appliance unless they are constantly supervised.
- ▶ Cleaning and user maintenance shall not be made by children without supervision.
- ▶ The appliance must be positioned so that the plug is accessible
- ▶ If coal gas or other inflammable gas is leaking into vicinity of the appliance, turn off the valve of the leaking gas, open the doors and windows and do not unplug the power cable of the refrigerator/freezer or any other appliance.
- ▶ Notice that the appliance is set for operation at the specific ambient range between 10 and 38°C. The appliance may not work properly if it is left for a long period at a temperature above or below the indicated range.
- ▶ Do not place unstable articles (heavy objects, containers filled with water) on top of the refrigerator/freezer, to avoid personal injury caused by falling or electric shock caused by contact with water.
- ▶ Do not pull on the door shelves. The door may be pulled slant, the bottle rack may be pulled away, or the appliance may topple.



WARNING!

- ▶ Open and close the door only with the handles. The gap between the door and the cabinet is very narrow. Do not put your hands in these areas to avoid pinching your fingers. Open or close the refrigerator/freezer doors only when there are no children standing within the range of door movement.
- ▶ Never store bottled beer or beverages, liquids in bottles or cans (besides high percentage spirits) especially carbonated beverages in the freezer, as these will burst during freezing.
- ▶ Do not store explosive substances such as aerosol cans with a flammable propellant in this appliance.
- ▶ Do not store medicines, bacteria or chemical agents in the appliance. This appliance is a household appliance. It is not recommended to store materials that require strict temperatures.
- ▶ Check the condition of food if a warming in the freezer has taken place.
- ▶ Do not set unnecessarily low temperature in the refrigerator compartment. Minus temperatures may occur at high settings. Attention: Bottles can burst
- ▶ Do not touch frozen goods with wet hands (wear gloves). Especially do not eat ice lollies immediately after removal from the freezer compartment. There is the risk to freeze or the formation of frost blisters. FIRST aid: keep immediately under running cold water. Do not pull away!
- ▶ Do not touch the inside surface of the freezer storage compartment when in operation, especially with wet hands, as your hands may freeze onto the surface.
- ▶ Unplug the appliance in the event of a power interruption or before cleaning. Allow at least 7 minutes before restarting the appliance, as frequent starting may damage the compressor.
- ▶ **WARNING:** Do not use electrical appliances inside the food storage compartments of the appliance, unless they are of the type recommended by the manufacturer.

**WARNING!****Maintenance / cleaning**

- ▶ Make sure children are supervised if they carry out cleaning and maintenance.
- ▶ Disconnect the appliance from the electrical supply before undertaking any routine maintenance. Allow at least 7 minutes before restarting the appliance, as frequent starting may damage the compressor.
- ▶ Hold the plug, not the cable, when unplugging the appliance.
- ▶ Do not clean the appliance with hard brushes, wire brushes, detergent powder, petrol, amyl acetate, acetone and similar organic solutions, acid or alkaline solutions. Please clean with special refrigerator/freezer detergent to avoid damage. Eventually use warm water and baking soda solution - about a tablespoon of baking soda to a litre/quart of water. Rinse thoroughly with water and wipe dry. Do not use cleaning powders or other abrasive cleaners. Do not wash removable parts in a dishwasher.
- ▶ Do not scrape off frost and ice with sharp objects. Do not use sprays, electric heaters like heater, hair dryer, steam cleaners or other sources of heat in order to avoid damage to the plastic parts.
- ▶ **WARNING:** Do not use mechanical devices or other means to accelerate the defrosting process, other than those recommended by the manufacturer.
- ▶ If the supply cord is damaged, it must be replaced by the manufacturer, its service agent or similarly qualified persons in order to avoid a hazard.
- ▶ Do not try to repair, disassemble or modify the appliance by yourself. In case of repair please contact our customer service.
- ▶ If the illuminating lamps are damaged, it must be replaced by the manufacturer, its service agent or similarly qualified persons in order to avoid a hazard.
- ▶ Eliminate the dust on the back of the unit at least once in the year to avoid hazard by fire, as well as increased energy consumption.

- ▶ Do not spray or flush the appliance during cleaning.
- ▶ Do not use water spray or steam to clean the appliance.
- ▶ Do not clean the cold glass shelves or glass door with hot water. Sudden temperature change may cause the glass to break.
- ▶ If you leave your appliance out of use for an extended period, leave it open to prevent odour and unpleasant smells building up inside.

Refrigerant gass information



WARNING!

The appliance contains the flammable refrigerant ISOBUTANE (R600a). Make sure the refrigerant circuit is not damaged during transportation or installation. Leaking refrigerant may cause eye injuries or ignite. If a damage has occurred, keep away open fire sources, thoroughly ventilate the room, do **not** plug or unplug the power cords of the appliance or any other appliance. Inform the customer service.

In case of eyes get into contact with the refrigerant, rinse it immediately under running water and call immediately the eye specialist.

WARNING: The refrigeration system is under high pressure. Do not tamper with it. Since the flammable refrigerants are used, please, install, handle and service the appliance strictly according to the instruction and contact the professional agent or our after-sales service to dispose of the appliance.



WARNING!

For refrigerators with ice-water function, please pay attention to the following warning:

For appliances not intended to be connected to the water supply:

WARNING: fill with potable water only.

For appliances intended to be connected to the water supply:

WARNING: connect to potable water supply only.

If you want to clean the water system, please refer to the User Manual. If you have any questions, please contact the after-sales service.

2.1 Intended use

This appliance is intended to be used in household and similar applications such as

- staff kitchen areas in shops, offices and other working environments;
 - farm houses and by clients in hotels, motels and other residential type environments;
 - bed and breakfast type environments;
 - catering and similar non-retail applications.
- ▶ If the appliance is not used for an extended period of time, and you will use only the Holiday-function or the fridge off function for the refrigerator/freezer:
- Take out the food.
 - Unplug the power cord.
 - Empty and clean the water tank.
 - Clean the appliance as described above.
 - Keep the doors open to prevent the creation of bad odours inside.
- ▶ To ensure the safe preservation of foodstuffs or wine, please comply with this instruction to use.
- ▶ The appliance should be cleaned at least once every four weeks for good maintenance and to prevent stored food odours. Always keep the door gasket clean.
- (1.) Please scrub the interior and exterior of the refrigerator, including door gasket, door rack, glass shelves, boxes and so on, with a soft towel or sponge dipped in warm water (neutral detergent can be added).
 - (2.) If liquids are accidentally spilled, all contaminated components should be removed and placed under the running water. After washing, wipe and dry.
 - (3.) If there is spilled cream (such as the cream, melting ice cream), please remove all the contaminated parts, put them into the warm water at about 40 °C for a while, then rinse with the flow water, dry and place it back into the refrigerator/freezer.
 - (4.) In case some small part or component enters inside of the fridge (between the shelves or drawers), use small soft brush to release it. If you could not reach the part, please contact Haier service.

- ▶ To avoid contamination of food, please respect the following instructions:
 - Opening the door for long periods can cause a significant increase of the temperature in the compartments of the appliance.
 - Clean regularly surfaces that can come in contact with food and accessible drainage systems.
 - Clean water tanks if they have not been used for 48 h; flush the water system connected to a water supply if water has not been drawn for 5 days.
 - Store raw meat and fish in suitable containers in the refrigerator/freezer, so that it is not in contact with or drip onto other food. To ensure the safe preservation of foodstuffs, instant food and raw meat / fish shall be stored separately.
 - Two-star frozen-food compartments are suitable for storing pre-frozen food, storing or making ice cream and making ice cubes.
 - One-, two- and three-star compartments are not suitable for the freezing of fresh food.
 - If the refrigerating appliance is left empty for long periods, switch off, defrost, clean, dry, and leave the door open to prevent mould developing within the appliance.
- ▶ The details on the most appropriate part in the compartment of the appliance where specific types of food shall be stored, considering the distribution of temperature that can be present in the different compartments of the appliance are in the other part of the manual.

Disposal



The  symbol on the product or on its packaging indicates that this product may not be treated as household waste. Instead it shall be handed over to the applicable collection point for the recycling of electrical and electronic equipment. By ensuring this product is disposed of correctly, you will help prevent potential negative consequences for the environment and human health, which could otherwise be caused by inappropriate waste handling of this product. For more detailed information about recycling of this product, please contact your local city office, your household waste disposal service or the shop where you purchased the product.

Since the flammable insulation blowing gases are used, please contact the professional agent or our after-sale service to dispose of the appliance.







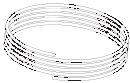

WARNING!

Risk of injury of suffocation!

Refrigerants and gases must be disposed of professionally. Ensure that the tubing of the refrigerant circuit is not damaged before being properly disposed of. Disconnect the appliance from the mains supply. Cut off the mains cable and dispose of it. Remove the trays and drawers as well as the door catch and seals to prevent children and pets to get closed in the appliance.

2.2 Accessories

Check the accessories and literature in accordance with this list (Fig. 2.2):

					2.2
					
Water pipe	Water filter	6.35mm adapter with valve	6.35mm adapter		
					
Egg tray	2 clips	Energy label	Warranty card	User manual	

I Notice

Due to technical changes and different models, some of the illustrations in this manual may differ from your model.

Picture of appliance (Fig. 3)

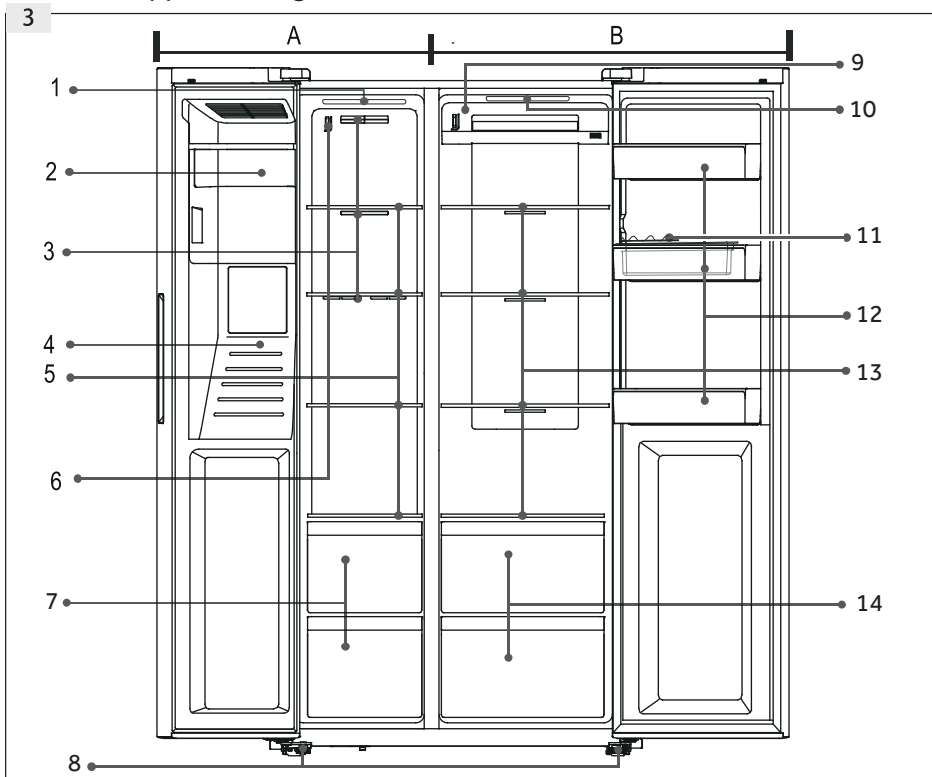

A: Freezer compartment

- 1 Ceiling camp
- 2 Ice maker with ice container
- 3 Air duct
- 4 Water and ice dispenser
- 5 Storage shelves
- 6 Sensor
- 7 Drawers

B: Fridge compartment

- 8 Adjustable feet
- 9 Air duct
- 10 Ceiling lamp
- 11 Egg tray
- 12 Door rack/bottle holder
- 13 Shelves
- 14 Drawers

Control panel (Fig. 4)

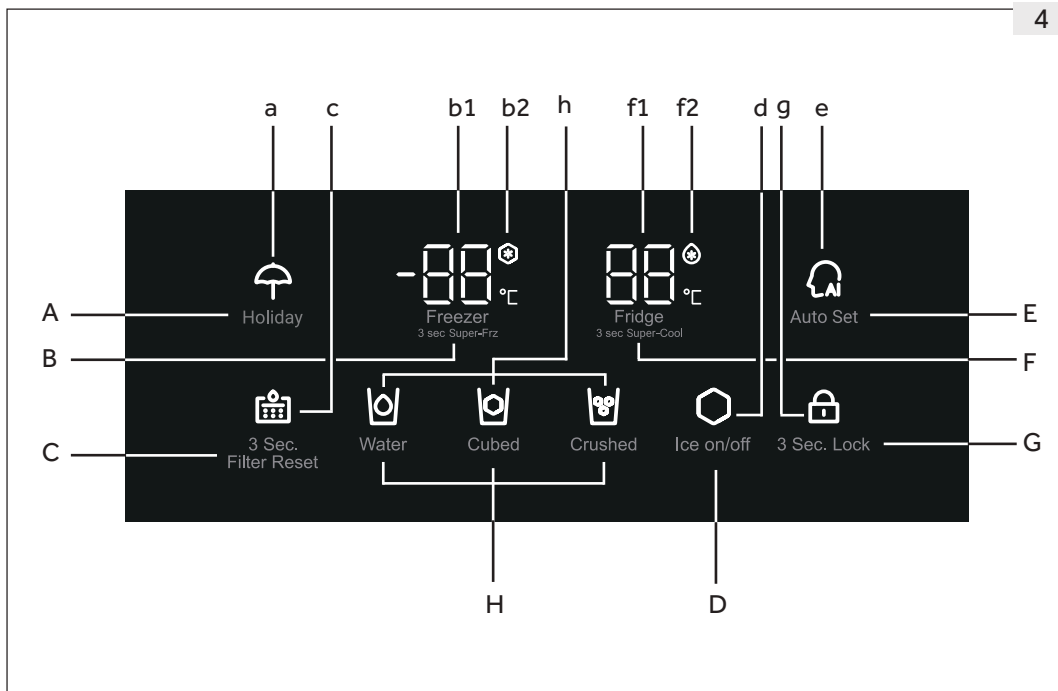
**Keys:**

- A Holiday function on/off
- B Freezer temperature adjustment
- C Filter Reset
- D Ice Maker function on/off
- E Auto Set function on/off
- F Fridge temperature adjustment
- G Panel lock selector
- H Dispenser function selection

Indicators:

- a Holiday mode
- b1 Temperature of freezer
- b2 Super-Freeze mode
- c Filter change status
- d Ice Maker status
- e Auto Set status
- f1 Temperature of fridge
- f2 Super-Cool mode
- g Panel lock
- h Dispenser status

5.1 Before first use

- ▶ Remove all packaging materials, keep them out of children's reach and dispose them in an environmentally friendly manner.
- ▶ Clean the inside and outside of the appliance, as well as the interior and accessories with water and a mild detergent and dry it well with soft cloth.
- ▶ After the appliance has been levelled and cleaned, wait for at least 2 hours before connecting it to the power supply. See Section INSTALLATION.
- ▶ Precool the compartments at high settings before loading with food. The function Super Cool and Super Freeze helps to cool down the compartments quickly.
- ▶ The refrigerator temperature and freezer temperature are automatically set to 5°C and -18 °C respectively. These are the recommended settings. If desired, you can change these temperatures manually. Please see Manual adjusting mode.

5.2 Sensor keys

The keys on the control panel are sensor keys, which could respond when lightly touched with the finger.

5.3 Switching the appliance on /off

The appliance is in operation as soon as it is connected to the power supply. The temperatures displayed will show the actual temperatures in the compartment. The panel lock might be active.

Empty the appliance before switching it off. To switch off the appliance, pull the power cord out off the power socket.



Notice: Presettings

- ▶ The appliance is preset to the recommended temperature of 5°C (refrigerator) and -18 °C (freezer). Under normal ambient condition you need not to set a temperature.
- ▶ When the appliance is switched on after disconnection from the main power supply, it may take up to 12 hours for the correct temperatures to be reached.

5.4

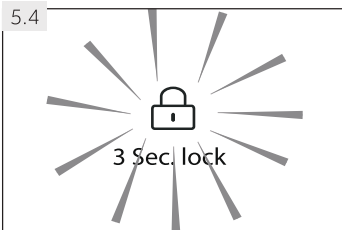

5.4 Lock/unlock panel

- ▶ Touch key "G" (3 Sec. Lock) for 3 seconds to block the temperature and function setting keys against activation.
- ▶ The indicator "g" lights up (Fig. 5.4) and the illumination of the panel is switched off. The icon flashes if a key is touched while the panel lock is activated.
- ▶ To unlock the panel, touch the key again for 3 seconds.



Notice: Panel lock

The control panel is automatically blocked against activation if no key is touched for 30 seconds. For any settings except dispenser function, the control panel must be unlocked.

5.5 Standby-mode

The display screen turns off automatically 30 seconds after a key was touched. The display is locked automatically. It lights up automatically when any key is touched or one of the doors is opened.

5.6 Door opening alarm

When a door is left open for more than 1 minute, the door opening alarm sounds. The alarm can be silenced by closing the door. If the door is left open for more than 7 minutes, the light inside the compartment automatically switches off.

5.7 Select the working mode

You need to select one of the following two ways to set the appliance:

5.7.1 Auto Set mode

If you do not have any special requirements, we recommend that you use Auto Set mode: In this mode, the appliance automatically adjusts the temperature setting according to the ambient temperature and temperature change in the appliance.

1. Unlock the panel by touching key "G" if it is locked (Fig. 5.4).
2. Touch key "E" (Auto Set) (Fig. 5.7.1-1)
3. Indicator "e" lights up and the function is activated (Fig. 5.7.1-2).

By repeating the above steps or selecting Holiday/Super-Freeze/Super-Cool mode, this function can be switched off again.

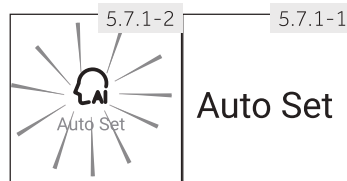

Notice: Auto Set mode

In Auto Set mode, the temperature of the fridge and freezer cannot be adjusted manually.

5.7.2 Manual adjusting mode

If you want to manually adjust the temperature of the appliance in order to store a particular food, you can set the temperature via a temperature adjusting key:

5.7.2.1 Adjust the temperature of the fridge

1. Unlock the panel by touching key "G" if it is locked (Fig. 5.4).
2. Touch key "F" (Fridge) to select the fridge compartment. The temperature in the fridge compartment (f1) starts flashing (Fig. 5.7.2-1).
3. Touch key "F" (Fridge) repeatedly until the desired temperature is flashing (Fig. 5.7.2-2). A signal will sound at each key touch. The temperature increases in sequences of 1 °C from a minimum of 1 °C to a maximum of 9 °C. The optimum temperature in the fridge is 5 °C. Colder temperatures mean unnecessary energy consumption.
4. Touch any key except "F" (Fridge) to confirm, or the setting confirms automatically after 5 seconds. The displayed temperature stops flashing.

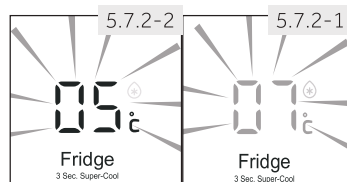

**Notice: Conflict with other functions**

The temperature cannot be adjusted, if any other function (Super Cool, Super Freeze, Holiday or Auto Set) is activated or the display is locked. The corresponding indicator will flash accompanied by a buzzer.

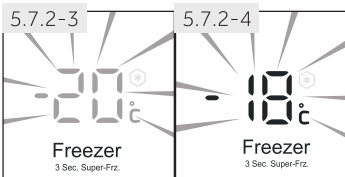
**5.7.2.2 Adjust the temperature of the freezer**

1. Unlock the panel by touching key "G" if it is locked (Fig. 5.4).
2. Touch key "B" (Freezer) to select the freezer compartment. The temperature in the freezer compartment (b1) starts flashing (Fig. 5.7.2-3).
3. Touch key "B" (Freezer) repeatedly until the desired temperature is flashing (Fig. 5.7.2-4). A signal sounds at each key press. The temperature increases in sequences of 1 °C from -14 °C to -24 °C. The optimum temperature in the freezer is -18 °C. Colder temperatures mean unnecessary energy consumption.
4. Touch any key except "B" (Freezer) to confirm, or the setting confirms automatically after 5 seconds. The displayed temperature stops flashing.

**Notice: Influences on temperature**

The indoor temperatures are influenced by the following factors:

- ▶ Ambient temperature
- ▶ Amount of stored foods
- ▶ Frequency of door opening
- ▶ Installation of the appliance

5.8

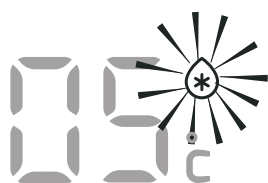
**5.8 Super-Cool function**

Switch on the Super-Cool function if you want to add a large quantity of food at once (for example after purchase). The Super-Cool function accelerates the cooling of fresh food and protects the goods already stored from undesirable warming.

1. Unlock the panel by touching key "G" if it is locked (Fig. 5.4).
2. Touch key "F" (Fridge) for 3 seconds. Indicator "f2" lights up and the function is activated. (Fig. 5.8).

The same operation stops the Super-Cool function.

**Notice: Automatic switch off**

- ▶ This function will automatically disabled after approximately 6h. ..
- ▶ The function is also disabled if the Auto Set mode or Holiday function is chosen.

5.9 Super-Freeze function

Fresh food should be frozen to the core as quickly as possible. This preserves the best nutritional value, appearance and taste. The Super-Freeze function accelerates the freezing of fresh food and protects the goods already stored from undesirable warming. If you need to freeze a large amount of food at once, it is recommended to set the Super-Freeze function ahead of time 12 h before adding the food.

1. Unlock the panel by touching key "G" if it is locked (Fig. 5.4).
2. Touch key "B" (Freezer) for 3 seconds. Indicator "b2" lights up and the function is activated. (Fig. 5.9).

The same operation stops the Super-Freeze function.

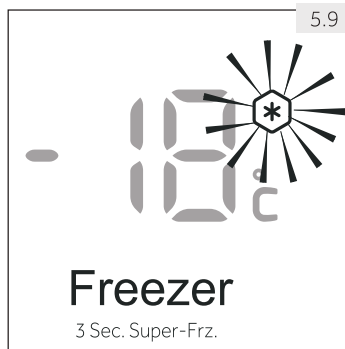

Notice: Automatic switch off

- ▶ The Super-Freeze function automatically switches off after approximately 50h.
- ▶ The function is also disabled if the Auto Set mode or Holiday function is chosen.

5.10 Holiday function

This function sets the fridge temperature to 17 °C.

This allows to keep the door of the empty fridge closed without causing an odour or mold during a long absence (e.g. during holiday). The freezer compartment is not affected by this setting.

1. Unlock the panel by touching key "G" if it is locked (Fig. 5.4).
2. Touch key "A" (Holiday) for 3 seconds. Indicator "a" lights up and the function is activated (Fig. 5.10).

By repeating the above steps or selecting another function this function can be switched off.



WARNING!

When the Holiday function is activated, no goods must be stored in the fridge compartment. The temperature of + 17 °C is too high to store food.

5.11

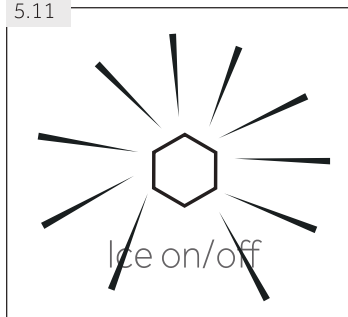

5.11 Ice Maker function

This function allows to produce ice, which can be removed through the dispenser.

The ice maker periodically receives an automatic flow of water which is frozen into ice cubes. Capacity of the ice maker depends on the ambient temperature, frequency of freezer door openings, and the temperature setting of the freezer compartment. The maximum quantity of ice production per day is 1.1 kg if the freezer temperature is set at -24 °C under the 25 °C ambient temperature condition.

1. Make sure the water supply valve is opened.
2. Unlock the panel by touching key "G" if it is locked (Fig. 5.4).
3. Touch key "D" (Ice on/off).
4. Indicator "d" lights up and the function is activated (Fig. 5.11).

By repeating step 2- step 4, this function can be switched off again.



Notice: Ice Maker function

- ▶ When the application is powered on, the ice maker is off by default.
- ▶ When you don't need ice cubes for a long period of time, please turn off the Ice Maker function, empty the container and insert the cleaned container.
- ▶ The icemaker can only be configured with manufacturer or purchased from its service agent.

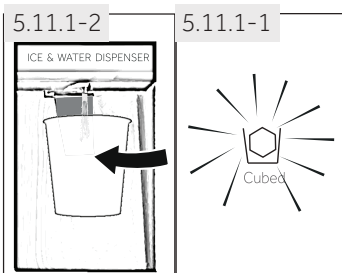

5.11.1 Getting ice cubes from the dispenser

1. Press the "Cubed" key to select ice cubes. The "Cubed" icon lights up (Fig. 5.11.1-1).
2. Place a glass under the water and ice dispenser (Fig. 5.11.1-2) on the front of the appliance.
3. Make sure the glass is close to the dispenser outlet to prevent ice cubes from falling out.
4. Push the glass against the lever. Ice cubes fall into the glass.



Notice: Getting ice

- ▶ When the appliance is switched on for the first time and if you start the ice function while the container is empty, it may take up to 24 hours to make your first batch of ice cubes.
- ▶ The first production of ice cubes (approx. 20 pieces) should not be consumed after first use, after a long non-use of the Ice Maker function and after a filter change.



Notice: Getting ice

- ▶ Do not take the filled ice container out off the freezer longer than necessary as ice cubes may melt.
- ▶ In periods of infrequent ice withdrawal, cubes may stick together. This is normal.
- ▶ If ice cubes get stale, throw them away and clean the ice container.
- ▶ 3 seconds after the delivery of ice, the dispenser flap closes with a 'phutt' sound. Don't remove the glass for 2 to 3 seconds as additional water or ice might be produced.
- ▶ Crushed ice might be dispensed instead of cubed ice if crushed ice was the last option selected.
- ▶ Do not place ice cubes which were not produced by the icemaker into the ice container to prevent damage to the mechanism.
- ▶ You can switch the setting of the dispenser to Water, Cubed, or Crushed even when the display is locked.

5.11.2 Getting crushed ice from the dispenser

1. Press the "Crushed" key to select crushed ice, The "Crushed" icon lights up (Fig. 5.11.2).
2. Place a glass under the water and ice dispenser (Fig. 5.11.1-2) on the front of the appliance.
3. Make sure the glass is close to the dispenser outlet to prevent crushed ice from falling out.
4. Push the glass against the lever. Crushed ice falls into the glass.



WARNING!

- ▶ Do not use deep, narrow, fragile or delicate glasses or paper cups with the dispenser.
- ▶ Never place canned drinks or food inside the ice container, as this will damage the crushing mechanism.
- ▶ Do not remove the cover of the ice maker to avoid accidental injury or damage to the appliance.

5.12 Cool Water function

With this function the tank in the fridge is filled automatically with drinking water which is cooled to drinking temperature and can be tapped.

1. Make sure the water supply valve is opened.
2. Touch key (Water) (Fig. 5.12-1).
3. Indicator lights up, the function is activated (Fig. 5.12-2) and water can be tapped.

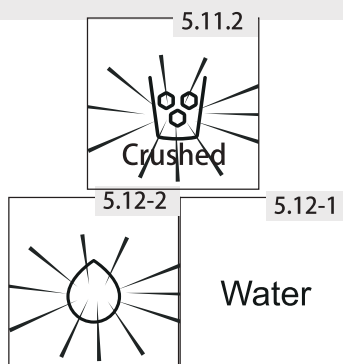

5.12.1 Getting water from the dispenser

1. Press the "Water" key to select cool water. The Water icon lights up.
2. Place a glass underneath the water and ice dispenser (Fig. 5.11.1-2) on the front of the appliance.
3. Make sure the glass is in line with the dispenser to prevent water from splashing out.
4. Push the glass against the lever. Water flows into the glass.



Notice: Water dispenser

- ▶ For the first use it is necessary to press the dispenser lever for 3 minutes in order to clear the air in the line.
- ▶ The first 7 glasses of water should not be consumed after initial start up or following a lengthy break in use.
- ▶ The first few glasses of water you take out are warmer than the next glasses. This is normal.
- ▶ If you like very cold water put some ice cubes from the ice container into the glass.
- ▶ Water in the tray should be removed, as it could spill when the door opens and closes.

5.13

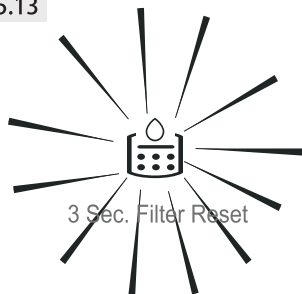

5.13 Change filter indicator

Approximately every 6 months, the "Change Filter" indicator light turns on (Fig. 5.13). This indicates that the water filter has to be changed. Refer to CARE AND CLEANING.

The filter in the water pipe absorbs impurities and makes water/ice clean and hygienic. After a long time of usage ice cubes can become smaller because the filter is blocked by the impurities.



Notice: Filter change

- ▶ For an impeccable quality of the ice cubes, it is important to change the water filter regularly. If the water quality shows signs of deterioration, either visually or in taste, the filter should be changed sooner – before the indicator light turns on.
- ▶ After installation of new filter the next production of ice cubes (20 pieces approx) or water (7 glasses approx) should not be consumed.

5.13.1 Reset the Change filter indicator

Touch key "C" (3 Sec. Filter Reset) for 3 seconds, The "Change Filter" indicator (c) becomes dark.



Notice: Reset Change filter indicator

To avoid diseases, do not deactivate the Change Filter indicator without changing the filter.

5.14 Tips on storing fresh food

5.14.1 Storing into the fridge compartment

- ▶ Keep your fridge temperature below 5 °C.
- ▶ Hot food must be cooled to room temperature before storing in the appliance.
- ▶ Foods stored in the fridge should be washed and dried before storing.
- ▶ Food to be stored should be properly sealed to avoid odour or taste alterations.
- ▶ Do not store excessive quantities of food. Leave spaces between foods to allow cold air flowing around them, for a better and more homogeneous cooling.
- ▶ Foods eaten daily should be stored at the front of the shelf.
- ▶ Leave a gap between foods and the inner walls, allowing air flow. Especially don't store foods against the rear wall: foods could freeze against rear wall. Avoid direct contact of food (especially oily or acidic food) with the inner liner, as oil/acid can erode the inner liner. Clean away oily/acid dirt whenever it is found.
- ▶ Defreeze frozen food in the fridge storage compartment. This way, you can use the frozen food to decrease the temperature in the compartment and save energy.
- ▶ The ageing process of fruit and vegetables such as courgettes, melons, papaya, banana, pineapple, etc. can be accelerated in the fridge. Therefore, it is not advisable to store them in the fridge. However, the ripening of strongly green fruits can be promoted for a certain period. Onions, garlic, ginger and other root vegetables should also be stored at room temperature.
- ▶ Unpleasant odours inside the fridge are a sign that something has spilled and cleaning is required. See CARE AND CLEANING.
- ▶ Different kinds of food should be placed in different areas according to their properties (Fig. 5.14.1):

- 1 Butter, cheese etc.
- 2 Eggs, canned food, spices etc.
- 3 Drinks and bottled foods.
- 4 Pickled foods, canned food, etc.
- 5/6 Meat products, fish, raw food
- 7 Cans, dairy products etc.
- 8 Fruits, vegetables, lettuce, etc
- 9 Cooked meat, sausages, etc.

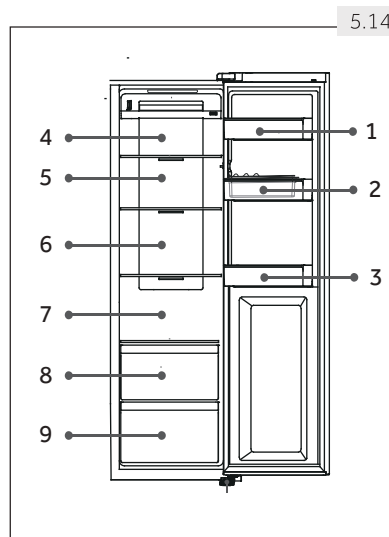

5.14.2 Storage into the freezer compartment

- ▶ Keep the freezer temperature at -18°C .
- ▶ 12 hours before freezing additional items switch on the Super-Freeze function; for small quantities of food 4-6 hours are sufficient.
- ▶ Hot food must be cooled to room temperature before storing in the freezer compartment.
- ▶ Food cut into small portions will freeze faster and is easier to defrost and cook. The recommended weight for each portion is less than 2.5 kg
- ▶ It is better to pack food before putting it into the freezer. The outside of the packaging must be dry to avoid bags sticking together. Packaging materials should be odour-free, airtight, non-poisonous and nontoxic.
- ▶ In order to avoid expiration of storage periods, please note the freezing date, time limit and name of the food on the packaging according to the storage periods of different foods.
- ▶ **WARNING!:** Acid, alkali and salt etc. could erode the internal surface of the freezer. Do not place the food having these substances (e.g. sea fish) directly on the internal surface. Salt water in the freezer should be cleaned up immediately.
- ▶ Do not exceed the food storage times recommended by the manufacturers. Only take the required amount of food out of the freezer.
- ▶ Different kinds of food should be placed in different areas according to their properties (Fig. 5.14.2):

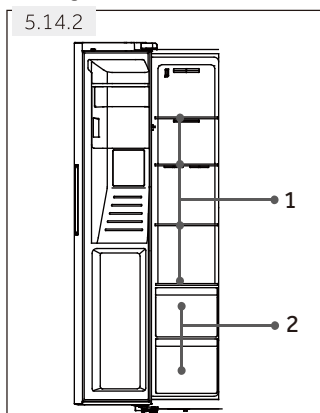

- 1 Less weighty items, such as ice cream, vegetables, bread etc.
- 2 Large/heavier portions of food, such as meat joints for roasting



Notice: Storage

- ▶ Please keep a distance of more than 10 mm between the food and the sensor to ensure the cooling effect.
- ▶ Please leave the lowest drawer in the appliance when it is working in order to ensure the cooling effect.
- ▶ Food items that include ice (like ice cream etc.) should be stored inside the freezer compartment instead of in the bottle holders. The temperature changes the bottle holders are exposed to, caused by opening and closing the door, may thaw the food.

- ▶ Consume defrosted food quickly. Defrosted food cannot be re-frozen unless it is firstly cooked, otherwise it may become inedible.
- ▶ Do not load excessive quantities of fresh food in the freezer compartment. Refer to the freezing capacity of the freezer – See TECHNICAL DATA or data at the type plate.
- ▶ Food can be stored in the freezer at a temperature of at least -18 °C for 2 to 12 months, depending on its properties (e.g., meat: 3-12 months, vegetables: 6-12 months)
- ▶ When freezing fresh food, avoid bringing it in contact with already frozen food. Risk of thawing!
- ▶ Defreeze frozen food in the fridge. This way, you can use the frozen food to decrease the temperature in the compartment and save energy.

5.14.3 When storing commercially frozen foods, please follow these guidelines:

- ▶ Always follow manufacturers' guidelines for the length of time you should store food for. Do not exceed these guidelines!
- ▶ Try to keep the length of time between purchase and storage as short as possible to preserve food quality.
- ▶ Buy frozen foods, which have been stored at a temperature of -18 °C or below.
- ▶ Avoid buying food which has ice or frost on the packaging – This indicates that the products might have been partially defrosted and refrozen at some point – temperature rises affect the quality of food.



Energy saving tips

- ▶ Make sure the appliance is properly ventilated (see INSTALLATION).
- ▶ Do not install the appliance in direct sunlight or in the near of heat sources (e.g. stoves, heaters).
- ▶ Avoid unnecessarily low temperature in the appliance. The energy consumption increases the lower the temperature in the appliance is set.
- ▶ Functions like Super-Cool or Super-Freeze consume more energy.
- ▶ Allow warm food to cool down before placing it in the appliance.
- ▶ Open the appliance door as little and briefly as possible.
- ▶ Do not overfill the appliance to avoid obstructing the air flow.
- ▶ Avoid air within the food packaging.
- ▶ Keep door seals clean so that the door always closes properly.
- ▶ Defreeze frozen food in the fridge storage compartment.

■ The most energy-saving configuration requires the appliance keep drawers, food box and shelves on factory-fresh condition, and food should be placed as far as possible without blocking the air outlet of the duct.

7.1 Adjustable shelves

The height of the shelves can be adjusted to fit your storage needs.

1. To relocate a shelf, remove it first by uplifting its hind edge (1) and pulling it out (2) (Fig. 7.1).
2. To reinstall it, put it on the lugs on both sides and push it to the most rearward position until the rear of the shelf is fixed inside the slots in the sides

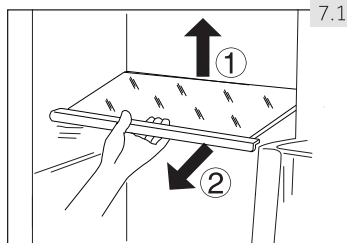

Notice: Shelves

Ensure that all ends of a shelf are level.

7.2 Removable door racks/bottle holder

The door racks/bottle holder can be removed for cleaning:

1. Place hands on each side of the rack/holder and lift it upwards (1) (Fig. 7.2).
2. Pull the door rack/bottle holder out (2).
3. In order to insert the door rack/bottle holder, the above steps are carried out in reverse order.

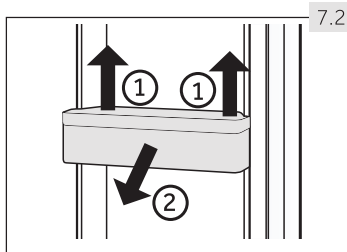

7.3 Removable drawer

To remove the drawer of the fridge or freezer compartment pull out to the maximum extent (1), lift and remove (2) (Fig. 7.3).

In order to insert the drawer, the above steps are carried out in reverse order.

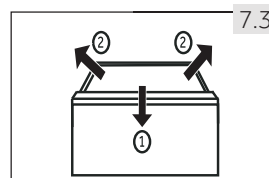

7.4 Ice container

7.4.1 Stopping the production of ice

If no ice or water is needed over a long period of time, the valve between the water supply and the appliance can be turned off.

The ice box should be cleaned, dried and put back into the appliance to prevent the emergence of odours.

7.4.2 Removing the ice container (Fig.7.4.2)

1. Grip both side handles.
2. Lift the container up.
3. Pull the container out.

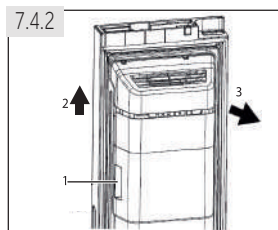

7.4.3 Reinstalling the ice container (Fig.7.4.3)

To reinstall the ice container, the U-shaped bracket behind the ice container (1 in Fig.7.4.3) must be aligned with the corresponding metal structure. Follow the steps from 7.4.2 in the reverse order.

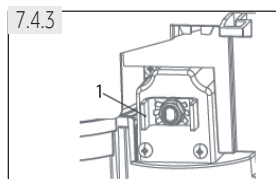

Notice: ice box

Moisture can condense and freeze the ice box in place.

7.5 The light

The LED interior light comes on when the door is opened. The performance of the lights is not affected by any of the appliance's other settings.

**WARNING!**

Disconnect the appliance from the power supply before cleaning.

8.1 General

Clean the appliance when only little or no food is stored.

The appliance should be cleaned every four weeks for good maintenance and to prevent bad stored food odors.

**WARNING!**

- ▶ Do not clean the appliance with hard brushes, wire brushes, detergent powder, petrol, amyl acetate, acetone and similar organic solutions, acid or alkaline solutions. Please clean with special fridge detergent to avoid damage.
 - ▶ Do not spray or flush the appliance during cleaning.
 - ▶ Do not use water spray or steam to clean the appliance.
 - ▶ Do not clean the cold glass shelves with hot water. Sudden temperature change may cause the glass to break .
 - ▶ Do not touch the inside surface of the freezer storage compartment, especially with wet hands, as your hands may freeze onto the surface.
 - ▶ In case of heating check the condition of frozen goods.
-
- ▶ Always keep the door gasket clean.
 - ▶ Clean the inside and housing of the appliance with a sponge dampened in warm water and neutral detergent (Fig. 8.1).
 - ▶ Rinse and dry with soft cloth.
 - ▶ Clean the accessories only with warm water and neutral detergent.
 - ▶ Do not clean any of the parts of the appliance in a dishwasher.
 - ▶ Allow at least 5 minutes before restarting the appliance as frequent starting may damage the compressor.

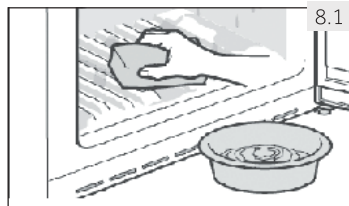
**8.2 Cleaning the ice container**

Clean the ice container periodically with warm water, especially if ice cubes get older and stale. Dry the container well before putting it back into the appliance in order to prevent ice cubes from sticking to the walls.

8.3 Defrosting

The defrosting of the fridge and the freezer compartment are done automatically; no manual operation is needed.

8.4 Replacing the LED-lamps



WARNING!

Do not replace the LED lamp yourself, it must only be replaced by either the manufacturer or the authorised service agent.

The lamps adopt LED as their light source, featuring low energy consumption and long service life. If there is any abnormality, please contact the customer service. See CUSTOMER SERVICE.

Parameters of the lamps: 12 V; max 3 W

8.5 Replacing the filter

The water filter has to be changed approximately every 6 months, when the "Change Filter" indicator light (c) lights up (Fig. 5.13).

The filter set can be ordered via the CUSTOMER SERVICE.



WARNING!

- ▶ Before replacing the filter deactivate the appliance and disconnect the mains plug from the mains socket.
- ▶ Turn off water supply.

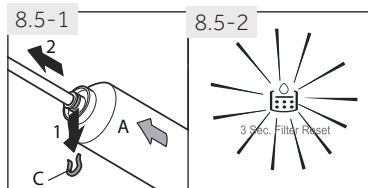

1. Remove (1) the locking clip (C) on both sides of the filter (A) and disconnect both pipes (2) (Fig. 8.5-1).
2. Install the new filter in correct position; the dart shows the direction of water flow. Repeat step 1 in reverse order.
3. Put the plug into the socket and open the water tab to flush the hoses.
4. Reset the "Change Filter" indicator: Touch key "C"(Filter reset) for 3 seconds, indicator "c" turns off (Fig.8.5-2).



WARNING!

- ▶ Ensure always that the connection is firm, dry and leak free!
- ▶ Take care the hose never to be crushed, kinked, or twisted.

8.6 Non-use for a longer period

If the appliance is not used for an extended period of time, and you do not want to use the Holiday-function for the fridge:

- ▶ Turn off the water supply (a few hours before you switch off the appliance).
- ▶ Take out the food.
- ▶ Empty and clean the ice container.
- ▶ Unplug the power cord.
- ▶ Clean the appliance as described above.
- ▶ Keep the doors open to prevent the creation of bad odours inside.
- ▶ Provide a new filter to install before the next use.



Notice: Switch off

Turn the appliance off only if strictly necessary.

8.7 Moving the appliance

1. Remove all food and unplug the appliance.
2. Secure shelves and other moveable parts in the fridge and the freezer with adhesive tape.
3. Do not tilt the appliance more than 45° to avoid damaging the refrigerating system.



WARNING!

- ▶ Do not lift the appliance by its handles.
- ▶ Never place the appliance horizontally on the ground.

Many occurring problems could be solved by yourself without specific expertise. In case of a problem please check all shown possibilities and follow below instructions before you contact an after sales service. See CUSTOMER SERVICE.



WARNING!

- ▶ Before maintenance, deactivate the appliance and disconnect the mains plug from the mains socket.
- ▶ Electrical equipment should be serviced only by qualified electrical experts, because improper repairs can cause considerable consequential damages.
- ▶ A damaged supply should only be replaced by the manufacturer, its service agent or similarly qualified persons in order to avoid a hazard.

9.1 Troubleshooting table

Problem	Possible Cause	Possible Solution
The compressor does not work.	<ul style="list-style-type: none"> • Mains plug is not connected in the mains socket. • The appliance is in the defrosting cycle. 	<ul style="list-style-type: none"> • Connect the mains plug. • This is normal for an automatic defrosting.
The appliance runs frequently or runs for a too long period of time.	<ul style="list-style-type: none"> • The indoor or outdoor temperature is too high. • The appliance has been off power for a period of time. • A door of the appliance is not tightly closed. • The door has been opened too frequently or for too long. • The temperature setting for the freezer compartment is too low. • The door gasket is dirty, worn, cracked or mismatched. • The required air circulation is not guaranteed. • The ice maker is running. 	<ul style="list-style-type: none"> • In this case, it is normal for the appliance to run longer. • Normally, it takes 8 to 12 hours for the appliance to cool down completely. • Close the door and ensure the appliance is located on a level ground and there is no food or container jarring the door. • Do not open the door too frequently. • Set the temperature higher until a satisfactory refrigerator temperature is obtained. It takes 24 hours for the refrigerator temperature to become stable. • Clean the door gasket or replace them by the customer service. • Ensure adequate ventilation. • This is normal. The ice maker adds extra work load.
The inside of the fridge is dirty and/or smells.	<ul style="list-style-type: none"> • The inside of the fridge needs cleaning. • Food of strong odour is stored in the fridge. 	<ul style="list-style-type: none"> • Clean the inside of the fridge. • Wrap the food thoroughly.
It is too cold inside the appliance.	<ul style="list-style-type: none"> • The temperature is set too low. • The Super-Cool / Super-Freezer function is activated or is running too long. 	<ul style="list-style-type: none"> • Reset the temperature. • Switch off the Super-Cool/ Super-Freezer function.

Problem	Possible Cause	Possible Solution
It is not cold enough inside the appliance.	<ul style="list-style-type: none"> The temperature is set too high. Too warm goods has been stored. Too much food has been stored at one time. The goods are too close to each other. A door of the appliance is not tightly closed. The door has been opened too frequently or for too long. 	<ul style="list-style-type: none"> Reset the temperature. Always cool down goods before storing them. Always store small quantities of food. Leave a gap between several foods allowing air flowing. Close the door. Do not open the door too frequently.
Moisture formation on the inside of the fridge compartment.	<ul style="list-style-type: none"> The climate is too warm and too damp. A door of the appliance is not tightly closed. The door has been opened too frequently or for too long. Food containers or liquids are left open. 	<ul style="list-style-type: none"> Increase the temperature. Close the door. Do not open the door too frequently. Let hot foods cool to room temperature and cover food and liquids.
Moisture accumulates on the fridges outside surface or between the doors.	<ul style="list-style-type: none"> The climate is too warm and too damp. The door is not closed tightly. The cold air in the appliance and the warm air outside it condensates. 	<ul style="list-style-type: none"> This is normal in damp climate and will change when the humidity decreases. Ensure that the door is tightly shut.
Strong ice and frost in the freezer compartment.	<ul style="list-style-type: none"> The goods were not adequately packaged. A door/drawer of the appliance is not tightly closed. The door has been opened too frequently or for too long. The door gasket is dirty, worn, cracked or mismatched. Something on the inside prevents the door to close properly. 	<ul style="list-style-type: none"> Always pack the goods well. Close the door/drawer. Do not open the door too frequently. Clean the door gasket or replace them by new ones. Reposition the shelves, door racks, or internal containers to allow the door to close.
The door does not close properly.	<ul style="list-style-type: none"> The refrigerator is not level. 	<ul style="list-style-type: none"> Make sure the floor is level and sturdy. Adapt adjustable feet.
The appliance makes abnormal sounds.	<ul style="list-style-type: none"> The appliance is not located on level ground. The appliance touches some object around it. 	<ul style="list-style-type: none"> Adjust the feet to level the appliance. Remove objects around the appliance.
Water drops collect in the lower drawers of the fridge.	<ul style="list-style-type: none"> Humidity levels are too high. 	<ul style="list-style-type: none"> Raise the compartment temperature of the fridge.

Problem	Possible Cause	Possible Solution
A slight sound can be heard, similar to that of flowing water.	<ul style="list-style-type: none"> This is normal. 	<ul style="list-style-type: none"> -
You hear an alarm beep.	<ul style="list-style-type: none"> The door is open. 	<ul style="list-style-type: none"> Close the door.
You hear a faint hum.	<ul style="list-style-type: none"> The anti-condensation system is working. 	<ul style="list-style-type: none"> This prevents condensation and is normal.
The interior lighting or cooling system does not work.	<ul style="list-style-type: none"> Mains plug is not connected in the mains socket. The power supply is not intact. The LED-lamp is out of order. The light switch is blocked. 	<ul style="list-style-type: none"> Connect the mains plug. Check the electrical supply to the room. Call the local electricity company! Please call the service for changing the lamp. Disconnect the power supply. Locate the light switch and move it a few times to see if this dislodges the stuck food.
The sides of the cabinet and door strip get warm.	<ul style="list-style-type: none"> This is normal. 	<ul style="list-style-type: none"> -
You can get no water from the water dispenser or no ice cubes	<ul style="list-style-type: none"> Water tap is closed. Inlet hose is kinked. Water pressure is less than 0.15 MPa Filter is blocked Door is not fully closed. Cool Water/Ice Maker function is not activated No ice cubes in the container Ice cubes are sticking together. Freezer temperature set too high. 	<ul style="list-style-type: none"> Check water tap. Check inlet hose. Check water pressure. Change the filter. Close the door. Activate Cool Water/Ice Maker function Wait until ice cubes are supplied. Take out the lump of ice cubes, crush it, and return to ice box. Lower the freezer temperature.
	Keep in mind that it may take up to 12 hours to produce the first ice cubes.	
Only small ice cubes are produced.	<ul style="list-style-type: none"> Filter must be changed. Water pressure is less than 0.15 MPa 	<ul style="list-style-type: none"> Change the filter Check water pressure
Ice dispenser is jammed.	<ul style="list-style-type: none"> Water has frozen to the spindle in the ice box. The spindle pushes the ice out. Ice cubes are jammed between the ice maker and the ice box. Other ice cubes were placed in the ice box. 	<ul style="list-style-type: none"> Remove the ice box. Clean and dry the spindle. Replace the box. Remove the ice cubes between the ice maker and ice box. Only ice cubes produced by the ice maker can be dispensed.

Problem	Possible Cause	Possible Solution
The ice cubes smell and taste unpleasantly.	<ul style="list-style-type: none"> Ice Maker function is not used often. Unpacked food is stored in the freezer compartment. 	<ul style="list-style-type: none"> Ice can take the smell and odour of other substances. Discard the ice cubes.
You hear sounds like flowing water or ice cubes dropping	<ul style="list-style-type: none"> This is normal when ice or water function is activated 	<ul style="list-style-type: none"> -
Water leaks out of the appliance	<ul style="list-style-type: none"> Water pressure is too high. Water hose is damaged. 	<ul style="list-style-type: none"> Interrupt the power supply, close the water tap and call the Customer Service
The control panel shows an error code.	<ul style="list-style-type: none"> An electric operating problem has occurred. 	<ul style="list-style-type: none"> Call the Customer Service.

9.2 Power interruption

In the event of a power cut, food should remain safely cold for about 5 hours. Follow these tips during a prolonged power interruption, especially in summer:

- ▶ Open the door/drawer as few times as possible.
- ▶ Do not put additional food into the appliance during a power interruption.
- ▶ If prior notice of a power interruption is given and the interruption duration is longer than 5 hours, make some ice and put it in a container in the top of the fridge compartment.
- ▶ An inspection of the goods is required immediately after the interruption.
- ▶ As temperature in the fridge will rise during a power interruption or other failure, the storage period and edible quality of food will be reduced. Any food that defrosts should be either consumed, or cooked and refrozen (where suitable) soon afterwards in order to prevent health risks.



Notice: Memory function during power interruption

After restoration of power the appliance continues with the settings that were set before the power failure.

10.1 Unpacking



WARNING!

- ▶ The appliance is heavy. Always handle with at least two persons.
- ▶ Keep all packaging materials out of children's reach and dispose them in an environmentally friendly manner.
- ▶ Take the appliance out of the packaging.
- ▶ Remove all packaging materials including the transparent protective film.

10.2 Environmental conditions

The room temperature should always be between 10 °C and 38 °C, since it can influence the temperature inside the appliance and its energy consumption. Do not install the appliance near other heat-emitting appliances (ovens, fridges) without isolation.

- Extended temperate(SN) : this refrigerating appliance is intended to be used at ambient temperatures ranging from 10 °C to 32 °C;
- Temperate(N) : this refrigerating appliance is intended to be used at ambient temperatures ranging from 16 °C to 32 °C;
- Subtropical(ST) : this refrigerating appliance is intended to be used at ambient temperatures ranging from 16 °C to 38 °C;
- Tropical(T) : this refrigerating appliance is intended to be used at ambient temperatures ranging from 16 °C to 43 °C;

10.3 Space requirement

Required space when door is opened (Fig. 10.3):

Appliance width: 158.8 cm

Appliance depth: 110.3 cm

10.4 Ventilation cross-section

To achieve sufficient ventilation of the appliance for safety reasons, the information of the required ventilation cross sections must be observed (Fig. 10.4).

Notice: For a free standing appliance: this refrigerating appliance is not intended to be used as a built-in appliance.

10.5 Fresh water connection

Follow the installation instructions below (Fig. 10.5-1 to Fig. 10.5-6).



WARNING!

- ▶ It is recommended to have the appliance installed by a qualified technician.
- ▶ Make sure that the mains plug is disconnected from the mains socket.
- ▶ Make sure the water supply is blocked.
- ▶ A shut-off valve which must be easy accessible after installation must be installed between the hose and the domestic water connection in order to be able to interrupt the water supply if necessary.
- ▶ Only connect to cold water supply.
- ▶ Use only the supplied hose set for the connection.

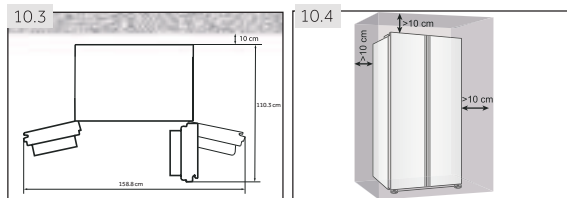



WARNING!

- ▶ Only connect to drinking water supply. The water filter only filters impurities in the water and makes ice clean and hygienic. It cannot sterilize or destroy germs or other harmful substances.
- ▶ Too high water pressure in the hose can damage the appliance. Install a pressure reducer when the water pressure in the hose exceeds 0.6 MPa.
- ▶ Before connection, check whether the water is clean and clear.



Notice: Water connection

- ▶ Pressure of the cold water has to be 0.15-0.6 MPa.
- ▶ The maximum permitted length of water hose is 8 meter. Longer hoses will affect the ice cubes and cold water content.
- ▶ Ambient temperature has to be 0 °C minimum.
- ▶ Keep the water hose away from heat sources.

1. Cut the pipe into two pieces with the required length to connect the filter (A) with the appliance (B1) and the water tap (B2) (Fig. 10.5-1). Make sure to get a square cut by using a sharp knife.

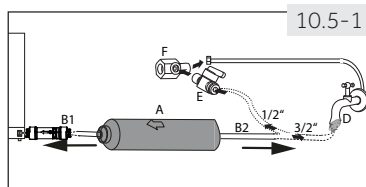

2. Insert pipe (B1) approx. 12 mm deep into the mounting fixture of the water filter (A) (Fig. 10.5-2). Take care to install the filter in the correct direction. The dart shows the direction of water flow.

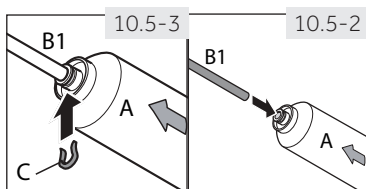

3. Secure the pipe with a locking clip (C) according to Fig. 10.5-3.

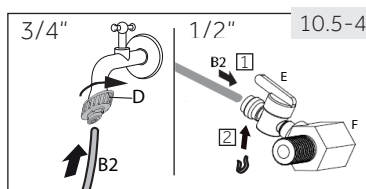

4. Repeat step 2 and 3 with the pipe (B2) on the other side of the filter

5. Connect the end of pipe (B2) to one of the adapters "D" or "E and F" which suits to the water main (Fig. 10.5-4).

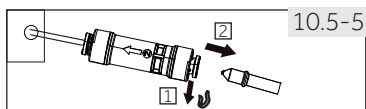

6. Remove the plug in the valve at the back of appliance (Fig.10.5-5).

7. Connect the end of B1 to the valve at the back of the appliance (Fig. 10.5-6).

8. Open the water tab to check if the system is leak free and flush the pipe.

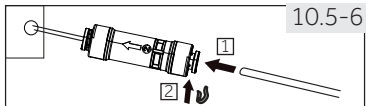

WARNING!

- ▶ Ensure that the connections are always firm, dry and leak free.
- ▶ Make sure the hose is never crushed, kinked, or twisted.

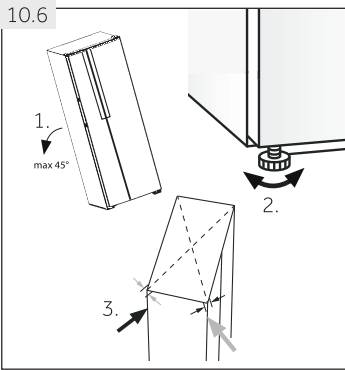

10.6 Aligning the appliance

The appliance should be placed on a flat and solid surface.

1. Tilt the appliance slightly backwards (Fig. 10.6).
2. Set the feet to the desired level.
Make sure the distance to the wall on the hinge sides is at least 10 cm.
3. The stability can be checked by alternately bumping on the diagonals. The slightly swaying should be the same in both directions. Otherwise the frame can warp; possible leaking door seals are the result. A low tendency to the rear facilitates the closing of the doors.

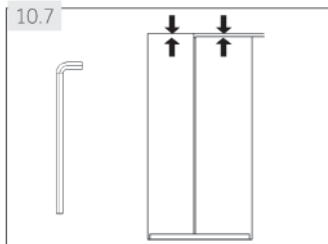

10.7 Fine tuning of the doors

If the doors are still not in one level after levelling the doors by the feet, this mismatch can be remedied by turning the hinge lifting shaft at the right bottom corner of refrigerating door with a spanner (Fig. 10.7)

Clockwise turn lifting shaft with spanner to lower door height (Fig. 10.7-1).

Anticlockwise turn lifting shaft with spanner to lift door height (Fig. 10.7-2).

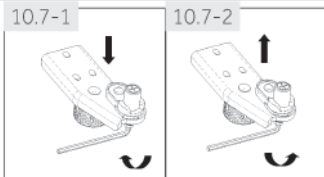

WARNING!

Do not adjust the hinge lifting shaft excessively to a height which might cause the shaft to leave its original locked position. (Adjustable height range: 3 mm)

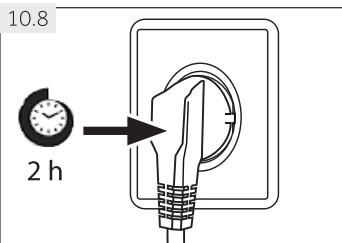

10.8 Waiting time

To the maintenance-free lubrication oil is located in the capsule of the compressor. This oil can get through the closed pipe system during slanting transport. Before connecting the appliance to the power supply you have to wait at least 2 hours (Fig.10.8) so that the oil runs back into the capsule.

10.9 Electrical connection

Before each connection check if:

- ▶ power supply, socket and fusing are appropriate to the rating plate.
- ▶ the power socket is earthed and no multi-plug or extension.
- ▶ the power plug and socket are strictly according.

Connect the plug to a properly installed household socket.



WARNING!

To avoid risks a damaged power cord must be replaced by the customer service (see warranty card).

10.10 Removing and installing the doors

In the event that you need to remove the appliance doors, please follow the door removal and installation instructions below (Fig. 10.10).



WARNING!

- ▶ Before any operation, deactivate the appliance and disconnect the mains plug from the mains socket.
- ▶ Block the water supply.
- ▶ The appliance is heavy. Always handle with at least two persons.
- ▶ Do not tilt the appliance more than 45° or place it horizontally on the ground
- ▶ The door may fall over and hurt people, or get damaged during these steps, please pay more attention when removing and installing doors.

1. Release the left side of two water couplers on the front left corner at the bottom of appliance: press and hold in the collar as shown and remove the water pipe. (Fig.10.10-1).

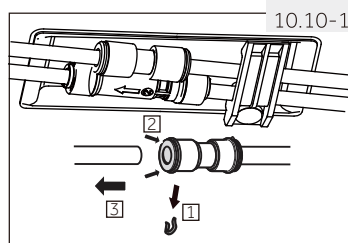

2. Undo the hinge cover screw and remove the cover (Fig. 10.10-2). When removing the freezer door, disconnect all wires except for the grounding wire.

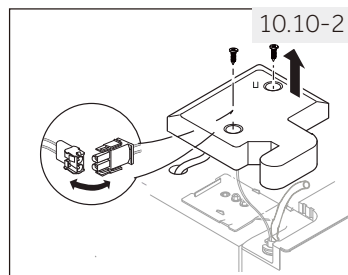

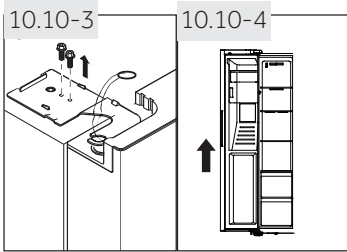

3. Undo the screws holding the upper hinge in position and then remove the hinge (Fig.10.10-3).
4. Lift the door to remove it (Fig.10.10-4). When removing the freezer door, lift it high enough to pull out the water connection from the bottom of the appliance.
5. Refit the door by reversing the removal steps. Ensure that the grounding cable will be fixed by the screw.
6. Refit the water connection.



Notice: Fridge door

The pictures show the removing of the freezer compartment door. For the fridge door please use the corresponding parts on the other side.

11.1 Product fiche according to regulation EU No. 2019/2016

Trade mark	Haier
Model identifier	HSR3918FI*/HSOBPIF9183 / HSOGPIF9183
Category of the model	Refrigerator-freezer
Energy efficiency class	F
Annual energy consumption (kWh/year) ¹⁾	393
Volume cooling (L)	337
Volume freezing (L)	178
Star rating	
Temperature of other compartments > 14 °C	Non applicable
Frostfree system	Yes
Temperature rise time (h)	5
Freezing capacity (kg/24h)	10
Climate class This appliance is intended to be used at an ambient temperature between 10 °C and 38 °C.	SN-N-ST
Noise emission class and airborne acoustical noise emissions (db(A) re 1pW)	C(40)
Construction type	Freestanding

¹⁾based on standard test results for 24 hours. Actual energy consumption will depend on how the appliance is used and where it is located.

11.2 Additional technical data

Total storage volume (L)	515
Voltage / Frequency	220-240V ~ / 50Hz
Defrosting input power (W)	200
Main fuse (A)	15
Coolant	R600a
Water pressure in MPa	0.15-0.6
Dimensions (H/W/D in mm)	1775/908/659

11.3 Standards and directives 

This product meets the requirements of all applicable EC directives with the corresponding harmonised standards, which provide for CE marking.

12-Custom service

EN

We recommend our Haier Customer Service and the use of original spare parts.
If you have a problem with your appliance, please first check section TROUBLESHOOTING.

If you cannot find a solution there, please contact

- ▶ your local dealer or
- ▶ the Service & Support area at www.haier.com where you can find telephone numbers and FAQs and where you can activate the service claim.

To contact our Service, ensure that you have the following data available.
The information can be found on the rating plate.

Model _____ Serial No. _____

Also check the Warranty Card supplied with the product in case of warranty.

For general business enquiries please find below our addresses in Europe:

European Haier addresses			
Country*	Postal address	Country*	Postal address
Italy	Haier Europe Trading SRL Via De Cristoforis, 12 21100 Verese ITALY	France	Haier France SAS 3-5 rue des Graviers 92200 Neuilly sur Seine FRANCE
Spain Portugal	Haier Iberia SL Pg. Garcia Faria, 49-51 08019 Barcelona SPAIN	Belgium-FR Belgium-NL Netherlands Luxembourg	Haier Benelux SA Anderlecht Route de Lennik 451 BELGIUM
Germany Austria	Haier Deutschland GmbH Hewlett-Packard-Str. 4 D-61352 Bad Homburg GERMANY	Poland Czechia Hungary Greece Romania Russia	Haier Poland Sp. zo.o. Al. Jerozolimskie 181B 02-222 Warszawa POLAND
United Kingdom	Haier Appliances UK Co.Ltd. One Crown Square Church Street East Woking, Surrey, GU21 6HR UK		

*For more information please refer to www.haier.com

***Duration of the guarantee of the refrigerating appliance:**

Minimum guarantee is: 2 years for EU Countries, 3 years for Turkey, 1 year for UK, 1 year for Russia, 3 years for Sweden, 2 years for Serbia, 5 years for Norway, 1 year for Morocco, 6 months for Algeria, Tunisia no legal warranty required.

***The period of spare parts for the repair of the appliance:**

Thermostats, temperature sensors, printed circuit boards and light sources are available for a minimum period of seven years after placing the last unit of the model on the market.

Door handles, door hinges, trays and baskets for a minimum period of seven years and door gaskets for a minimum period of 10 year, after placing the last unit of the model on the market.

***Technical Assistance**

To contact the technical assistance, visit our website: <https://corporate.haier-europe.com/en/>
Under the section “website”, choose the brand of your product and your country. You will be redirected to the specific website where you can find the telephone number and form to contact the technical assistance

* For further information about the product, please consult: <https://eprel.ec.europa.eu/>

*